

FEATURES

- **USB Type-C 2.0 and USB PD3.0 Compliance Certified, TID: 1000189, XID: 0005399**
 - Support 5V, 9V and 12V FPDOs
 - Support 5V Prog and 9V Prog APDOs
- **Support BC1.2 DCP and HVDCP Protocols**
 - BC1.2 DCP Mode
 - Divider 3 Mode
 - QC2.0/3.0 Class A
 - AFC
 - FCP and SCP
- **External N-MOSFET Supported**
- **Support Constant Voltage Loop (CV) and Constant Current Loop (CC) Operation**
- **Additional 7 Power Levels Configured by PS0, PS1 Pins**
- **Integrated OVP, UVP, UVLO, OCP, FOCP and TSD Protections**
- **16-Lead Plastic QFN (3mm × 3mm) Package**
- **±4kV HBM ESD Rating for USB IO Pins**

APPLICATIONS

- AC-DC Power Adaptor
- Car Charger

GENERAL DESCRIPTION

The **HUSB338C** is a high performance, high integration USB Type-C Power Delivery source controller. The **HUSB338C** supports PD2.0, PD3.0, PPS, QC2.0/3.0, Divider 3, BC1.2 DCP, AFC, FCP and SCP protocols. It supports 5V, 9V and 12V three FPDOs and 5V Prog, 9V Prog two APDOs which are fully compliant with USB Power Delivery Specification Revision 3.0, version 2.0.

The **HUSB338C** integrates all required protections such as Over Voltage Protection (OVP), Under Voltage Protection (UVP), Under Voltage Lock Out (UVLO), Over Current Protection (OCP), Fast Over Current Protection (FOCP) and Thermal Shut Down (TSD).

It is available in QFN-16L, 3mm x 3mm package.

TYPICAL APPLICATION CIRCUIT

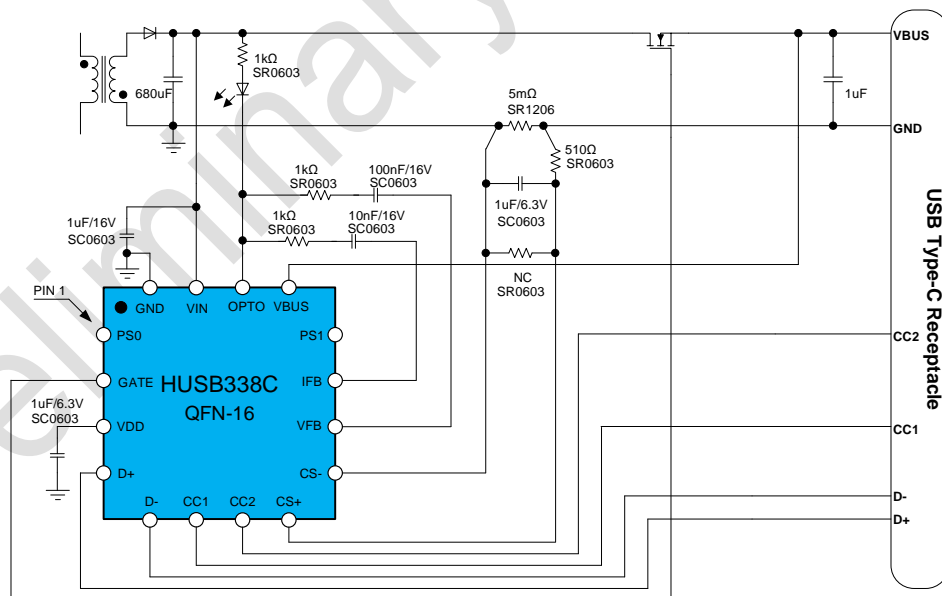

Figure 1. Typical Application Circuit

TABLE OF CONTENTS

Features1

Applications1

General Description1

Typical Application Circuit1

Table of Contents2

Revision History2

Pin Configuration and Function Descriptions3

Specifications4

Recommended Operating Conditions5

Absolute Maximum Ratings6

 Thermal Resistance6

 ESD Caution6

Theory of Operation7

 VIN Pin7

 VDD Pin7

 Control Loop Compensation Circuit (VFB, CS+, CS-, IFB, OPTO Pins)7

 CC1 and CC2 Pins7

 VBUS Pin8

 GATE Pin8

 Power Selection8

 Over Voltage Protection9

 Under Voltage Protection9

 Over Current Protection9

 Fast Over Current Protection9

 Thermal Shut Down9

 Charging Protocols Auto Selection (D+ and D- Pin)9

Typical Application Circuits11

Package Outline Dimensions12

Package TOP Marking12

Ordering Guide13

Important Notice14

REVISION HISTORY

Version	Date	Owner	Descriptions
Rev. 0.0	10/2021	Yingyang Ou	Initial version

PIN CONFIGURATION AND FUNCTION DESCRIPTIONS

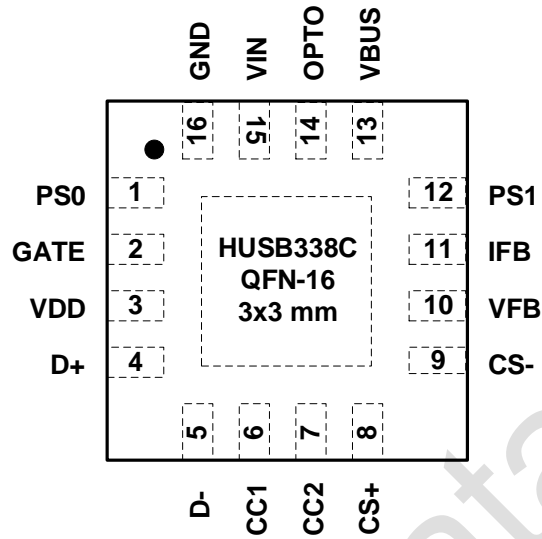

Figure 2. Pin Configuration (Top View)

Table 1. Pin Function Descriptions

Pin No.	Pin Name	Type ¹	Description
1	PS0	AI	Power selection input 0. Connect to ground or VDD, or keep floating can determine the output power level, combined with PS1 pin.
2	GATE	AO	N-MOSFET Gate driver output for VBUS load switch.
3	VDD	P	Internal 3.3V regulator output for system power.
4	D+	DIO	USB D+ line.
5	D-	DIO	USB D- line.
6	CC1	AIO	USB Type-C CC1 line.
7	CC2	AIO	USB Type-C CC2 line.
8	CS+	AI	Positive input of the current sense amplifier.
9	CS-	AI	Negative input of the current sense amplifier.
10	VFB	AI	Feedback point of Constant Voltage (CV) loop, connect CV compensation network to this pin.
11	IFB	AI	Feedback point of Constant Current (CC) loop, connect CC compensation network to this pin.
12	PS1	AI	Power selection input 1. Connect to ground or VDD, or keep floating can determine the output power level, combined with PS0 pin.
13	VBUS	AI	VBUS sense and discharge pin.
14	OPTO	AI	OPTO driver.
15	VIN	P	Supply voltage input. Connect this pin to GND via a recommended 1µF ceramic capacitor.
16	GND	P	Power ground.
-	PAD	-	QFN package pad. It is recommended to connect this pin to GND.

¹ Legend:
 A = Analog Pin
 P = Power Pin
 D = Digital Pin
 I = Input Pin
 O = Output Pin

SPECIFICATIONS

$V_{IN} = 5V$, $T_A = 25^{\circ}C$, unless otherwise noted.

Table 2.

Parameter	Symbol	Test Conditions/Comments	Min	Typ	Max	Unit
POWER SUPPLY						
Supply Voltage	V_{IN}		3.3		12	V
Supply Voltage UVLO Threshold	V_{IN_UVLO}	Rising edge		3.0		V
Supply Voltage UVLO Hysteresis	$V_{IN_UVLO_HYS}$			250		mV
Supply Current	I_{CC}	CC is attached, normal operation		2.6		mA
Quiescent Current	I_Q	CC1 and CC2 pins are floating		550		μA
VDD						
Internal Regulator Output	V_{DD}			3.3		V
Type-C						
1.5A Mode Pull-Up Current Source	I_{CC_1P5}		166	180	194	μA
3.0A Mode Pull-Up Current Source	I_{CC_3P0}		304	330	356	μA
UFP Detection Threshold at 1.5A Current	V_{TH_1A5}		1.51	1.6	1.64	V
UFP Detection Threshold at 3.0A Current	V_{TH_3A0}		2.46	2.6	2.74	V
BMC COMMAN PARAMETERS						
Bit Rate	$f_{BitRate}$		270	300	330	Kbps
BMC TX PARAMETERS						
Falling Time	t_{Fall}	10% and 90% amplitude points, unloaded condition	300			ns
Rising Time	t_{Rise}	10% and 90% amplitude points, unloaded condition	300			ns
Voltage Swing	V_{Swing}	CC pull down resistor > 800 Ω	1.05	1.125	1.2	V
Transmitter Low Voltage	V_{Low}	CC pull down resistor > 800 Ω	-75		75	mV
Transmitter Output Impedance	Z_{Driver}	Source output impedance at 750kHz with CC attached	35	55	75	Ω
BMC RX PARAMETERS						
RX Bandwidth Limiting Filter	$t_{RXFilter}$	Time constant of a single pole filter	100			ns
Input Signal Hysteresis				160		mV
Receiver Input Impedance	Z_{BMC_RX}		1			M Ω
BC1.2 DCP MODE						
D+ and D- Shorting Resistance	R_{DPM_SHORT}	$V_{D+} = 0.6V$		20	40	Ω
D+ Leakage Resistance	R_{DP_LKG}	$V_{D+} = 0.6V$		800		k Ω
D- Leakage Resistance	R_{DM_LKG}	$V_{D-} = 0.6V$		800		k Ω
DIVIDER3 MODE						
D+ Output Voltage	V_{DP_APP}	$V_{IN} = 5V$		2.7		V
D- Output Voltage	V_{DM_APP}	$V_{IN} = 5V$		2.7		V
D+ Output Impedance	R_{DP_PAD}	$I_{D+} = -5\mu A$		30		k Ω
D- Output Impedance	R_{DM_PAD}	$I_{D-} = -5\mu A$		30		k Ω
HVDCP MODE						
Output Voltage Selection Reference	V_{SEL_REF}			2.0		V
Data Detect Voltage	V_{DAT_REF}			0.325		V
D+ High Glitch Filter Time	$T_{GLITCH_BC_MODE}$		1	1.25	1.5	S
D- Low Glitch Filter Time	$T_{GLITCH_DM_LOW}$		1	2		ms
Output Voltage Glitch Filter Time	$T_{GLITCH_V_CHANGE}$		20	40	60	ms
D- Pull-Down Resistance	R_{DM_DWM}			15		k Ω

Parameter	Symbol	Test Conditions/Comments	Min	Typ	Max	Unit
QC MODE						
Pulse Glitch Filter Time	T _{GLITCH_CONT_CHANGE}	For QC3.0 in continues mode	100	150	200	μs
FCP MODE						
D- FCP TX Valid Output High	V _{TX_VOH}		2.55		3.6	V
D- FCP TX Valid Output Low	V _{TX_VOL}				0.3	V
D- FCP RX Valid Input High	V _{RX_VIH}		1.4		3.6	V
D- FCP RX Valid Input Low	V _{RX_VIL}				1	V
D- Output Pull-Low Resistance	R _{DMPL}			500		Ω
Unit Interval for FCP	UI			160		μs
VOLTAGE CONTROL (VFB PIN)						
Voltage Sense Scaling Factor				10		
VIN Step LSB				20		mV
Default Voltage	V _{IN_DEF}	CC is unattached		5.1		V
VIN Regulation Accuracy		VIN=3.3-12V	-5		5	%
CURRENT CONTROL (CS+, CS-, IFB PINs)						
Current Sense Resistor				5		mΩ
GATE PIN						
Driver Voltage		Refer to VIN		5		V
Sourcing Current		EN_GATE = 1		20		μA
Pull Down Resistance		EN_GATE transition from 1 to 0		200		Ω
OPTO PIN						
Minimum OPTO Current				30		μA
Maximum Pull Down Current				3		mA
OVER VOLTAGE PROTECTION						
OVP Protection Threshold	V _{IN_OV}	Reference to internal V _{IN} reference	115	120	125	%
OVP De-bounce Time	t _{OV_DEB}			10		μs
UNDER VOLTAGE PROTECTION						
UVP Protection Threshold	V _{IN_UV}	Reference to internal V _{IN} reference	75	80	85	%
UVP De-bounce Time	t _{UV_DEB}			1		ms
OVER CURRENT PROTECTION						
OCP Protection Threshold	I _{IN_OC}	Reference to internal I _{IN} reference		120		%
OCP De-bounce Time	t _{OC_DEB}			2.5		ms
FOCP Protection Threshold	I _{IN_SCP}			6		A
THERMAL SHUT DOWN						
Thermal Shut Down Threshold	T _{TSD}			150		°C
Thermal Shut Down Hysteresis	T _{TSD_HYS}			20		°C

RECOMMENDED OPERATING CONDITIONS

Table 3.

Parameter	Rating
VIN Input Voltage	3.15V to 12.6V
Operating Junction Temperature Range (T _J)	-40°C to 125°C
Ambient Temperature Range (T _A)	-40°C to 85°C

ABSOLUTE MAXIMUM RATINGS

Table 4.

Parameter	Rating
VIN, VBUS, OPTO, CC1	-0.3V to 16V
GATE	-0.3V to 24V
VDD, D+, D-, CS+, CS-, CC2, VFB, IFB	-0.3V to 7V
Junction Temperature Range	-40°C to +150°C
Soldering Conditions	JEDEC J-STD-020
Electrostatic Discharge (ESD)	
Human Body Mode (CC1, D+, D- and VBUS pins)	4000V
Human Body Mode (Other pins)	2000V
Machine Mode	500V

Stresses at or above those listed under Absolute Maximum Ratings may cause permanent damage to the product. This is a stress rating only; functional operation of the product at these or any other conditions above those indicated in the operational section of this specification is not implied. Operation beyond the maximum operating conditions for extended periods may affect product reliability.

THERMAL RESISTANCE

Thermal performance is directly linked to printed circuit board (PCB) design and operating environment. Close attention to PCB thermal design is required.

θ_{JA} is the natural convection junction to ambient thermal resistance measured in a one cubic foot sealed enclosure.

θ_{JC} is the junction to case thermal resistance.

Table 5. Thermal Resistance

Package Type	θ_{JA}	θ_{JC}	Unit
QFN-16L, 3mm x 3mm	69	39.7	°C/W

ESD CAUTION



Electrostatic Discharge Sensitive Device.

Charged devices and circuit boards can discharge without detection. Although this product features patented or proprietary protection circuitry, damage may occur on devices subjected to high energy ESD. Therefore, proper ESD precautions should be taken to avoid performance degradation or loss of functionality.

THEORY OF OPERATION

VIN PIN

VIN pin is the power supply input, which is derived from the output of the AC-DC or DC-DC converter. Connect a 1µF decoupling MLCC between VIN pin and GND pin.

The VIN pin is also connected to an internal MOSFET and discharge resistor, which is used as a bleeder to help discharge the energy stored in the output capacitor. With this bleeder, VIN can be regulated to vSafe5V upon the detachment of a connected device, or to a lower desired output voltage level upon a request command received from the Sink, such as from 12V to 5V.

VDD PIN

An internal linear regulator is used to provide 3.3V for internal circuits. Connect a 1µF MLCC to VDD pin for decoupling.

CONTROL LOOP COMPENSATION CIRCUIT (VFB, CS+, CS-, IFB, OPTO PINS)

In the HUSB338C, the constant voltage loop (CV loop) compensation and constant current loop (CC loop) compensation are implemented. VIN voltage is scaled by a resistor divider to be as the feedback voltage. It is compared with the internal voltage reference to generate an error signal. The CV loop can compensate this error signal. And then the compensated signal is employed to drive the primary side of the opto-coupler and control the AC-DC power loop.

SLEW RATE CONTROL

The HUSB338C implements a fixed voltage slew rate, which is 83mV/ms.

IR COMPENSATION

IR compensation is only available when VIN is set to 5V. If PPS is available in any power level, IR compensation will be disabled even if 5V APDO is selected. The default IR compensation is 100mV/A.

For example, if 100mV/A IR compensation is selected, then for the 5V/3A condition (except 5V APDO), the actual VIN voltage is:

$$5V + 3A \times 100mV/A = 5.3V$$

CURRENT SENSE RESISTOR

The recommended current sense resistor is 5mΩ. The sensed current information is employed to perform OCP, FOCP and Constant Current Control.

CC1 AND CC2 PINS

CC1 and CC2 pins are used to detect Type-C connection, BMC communication.

TYPE-C CC FUNCTION

CC1 and CC2 are the Configuration Channel pins used for connection and attachment detection, plug orientation determination and system configuration management across USB Type-C cable.

The HUSB338C monitors the status of CC1 and CC2 pins and decide which state the HUSB338C should enter.

CC1 and CC2 are configured as Source only mode with 1.5A and 3A current advertising. The default R_p current on CC1 and CC2 is I_{CC_3P0} , which means 3A current advertising.

The CC1 and CC2 can tolerance a voltage up to 16V. This is helpful for the HUSB338C to survive in the failure when the CC1 or CC2 is shorted to the VBUS pin.

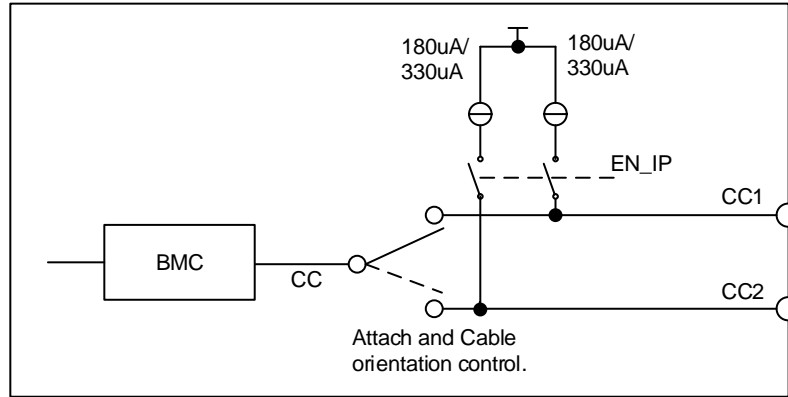

Figure 3. CCx Hardware Diagram

BMC DRIVER

Through the Type-C detection, one of the CC pins will be connected to the internal BMC block to achieve PD communication.

VBUS PIN

This pin is used to sense VBUS presence and discharge VBUS voltage on USB Type-C receptacle side.

VSAFE0V DETECTION

When the HUSB338C is attached with a Sink, it detects whether the VBUS voltage is within vSafe0V. If yes, the HUSB338C enters Attached.SRC state. If no, it will stay at AttachWait.SRC state.

VBUS DISCHARGE

The VBUS pin is also connected to an internal MOSFET and discharging circuitry, which is used as a bleeder to help dissipate the energy stored in the VBUS capacitor. With this bleeder, VBUS is discharged to vSafe0V upon the detachment of a connected device, or to a lower desired output voltage level upon a request command received from the Sink, such as from 12V to 5V.

GATE PIN

The GATE pin of the HUSB338C is designed to drive an external N-MOSFET. When the HUSB338C is attached and is ready to enable VBUS. The GATE pin outputs a voltage to turn on the external N-MOSFET. The turn on time of the external N-MOSFET may impacted by the external N-MOSFET's characteristics.

POWER SELECTION

The HUSB338C is 30W power level in default when PS0 and PS1 pins are floating. It is able to advertise a Source_Capabilities message with 5V, 9V, 12V FPDOs. The detailed power configuration of the HUSB338C shows as in Table 6.

Table 6. Power Configurations in Default

Power Parameters	Note
FPDO1	5V3A
FPDO2	9V3A
FPDO3	12V2.5A
APDO1	NA
APDO2	NA
IR Comp@5V	100mV/A
OCP Rating	120%
OVP Rating	120%
DPDM Modes	QC2.0/3.0, Divider 3, BC1.2 DCP, AFC, FCP and SCP

Besides, the source output power can be set into different power levels and different PDP options through different combination of the configurations of the PS0 and PS1 pins, as shown in Table 7.

Table 7. Source Power Selection

PS0	PS1	Source Power Level
Floating	Floating	30W (5V/3A, 9V/3A, 12V/2.5A)
Floating	GND	18W (5V/3A, 9V/2A, 12V/1.5A)
Floating	VDD	18W (5V/3A, 9V/2A, 12V/1.5A, 3.3V~5.9V/3A, 3.3V~11V/2A)
GND	Floating	20W (5V/3A, 9V/2.22A)
GND	GND	20W (5V/3A, 9V/2.22A, 12V/1.66A)
GND	VDD	20W (5V/3A, 9V/2.22A, 12V/1.66A, 3.3V~5.9V/3A, 3.3V~11V/2.2A)
VDD	Floating	25W (5V/3A, 9V/2.77A, 3.3V~5.9V/3A, 3.3V~11V/2.75A)
VDD	GND	27W (5V/3A, 9V/3A, 12V/2.25A)
VDD	VDD	27W (5V/3A, 9V/3A, 12V/2.25A, 3.3V~11V/3A)

OVER VOLTAGE PROTECTION

The HUSB338C detects the VIN pin voltage to achieve over-voltage protection function. The threshold to trigger over-voltage protection is 120% of the VIN_REF. When the over-voltage condition occurs, the HUSB338C disables the GATE pin. When the over-voltage condition is removed, the HUSB338C is reset to default mode and will automatic recover again.

UNDER VOLTAGE PROTECTION

The HUSB338C detects the VIN pin voltage to achieve under-voltage protection function. The threshold to trigger under-voltage protection is 80% of the VIN_REF. When the under-voltage condition occurs, the HUSB338C disables the GATE pin. When the over-voltage condition is removed, the HUSB338C is reset to default mode and will automatic recover again.

OVER CURRENT PROTECTION

When the current sensed by the sense resistor exceeds the 120% of IIN_REF, the over-current protection takes action and the GATE is also disabled. When the over-current condition is removed, the HUSB338C is reset to default mode and will automatic recover again.

FAST OVER CURRENT PROTECTION

The HUSB338C integrates FOCP protection function. When the VBUS is hard shorted to GND by fault, the output current increases sharply. When the output current reaches the FOCP threshold, the protections circuit takes action and turns off the external load switch. When the short condition is removed, the HUSB338C is reset to default mode and will automatic recover again.

THERMAL SHUT DOWN

When the junction temperature rises across T_{TSD}, thermal shut down takes action and the GATE is disabled. When the junction temperature falls across T_{TSD}-T_{TSD_HYS}, the HUSB338C is reset to default mode and will automatic recover again.

CHARGING PROTOCOLS AUTO SELECTION (D+ AND D- PIN)

The HUSB338C supports various fast charging protocols including BC1.2 DCP, Divider 3, QC 2.0/3.0 Class A, AFC, FCP and SCP. According to the different status of D+ and D- pins, the HUSB338C recognizes the attached Sinks and apply the fast charging protocol automatically.

DPDM_APP MODE

The DPDM_APP mode is the mode that the HUSB338C supports the Divider 3 charging protocol. In the DPDM_APP mode, the HUSB338C outputs 2.7 V DC voltage on both D+ and D- pins. The 2.7 V can be pulled down by the attached Sink. If D+ or D- pin is pulled down below V_{SEL_REF}, the HUSB338C exits the DPDM_APP mode and enters into DPDM_DCP mode.

DPDM_DCP MODE

The DPDM_DCP mode is the mode that the HUSB338C supports BC1.2 DCP protocol. The 2.7 V DC sources are removed and the D+ and D- pins are shorted through R_{DPM_SHORT} resistor. It is possible for the attached Sink to start primary, secondary and HVDCP detection processes when the HUSB338C is in DPDM_DCP mode.

DPDM_HVDCP MODE

After successful detection of the DCP, the **HUSB338C** notify the Sink that the **HUSB338C** enters into HVDCP mode. In the HVDCP mode, the **HUSB338C** monitors the D+/D- status and enters into different modes depending on the status of D+/D- pins.

Preliminary Datasheet

PACKAGE OUTLINE DIMENSIONS

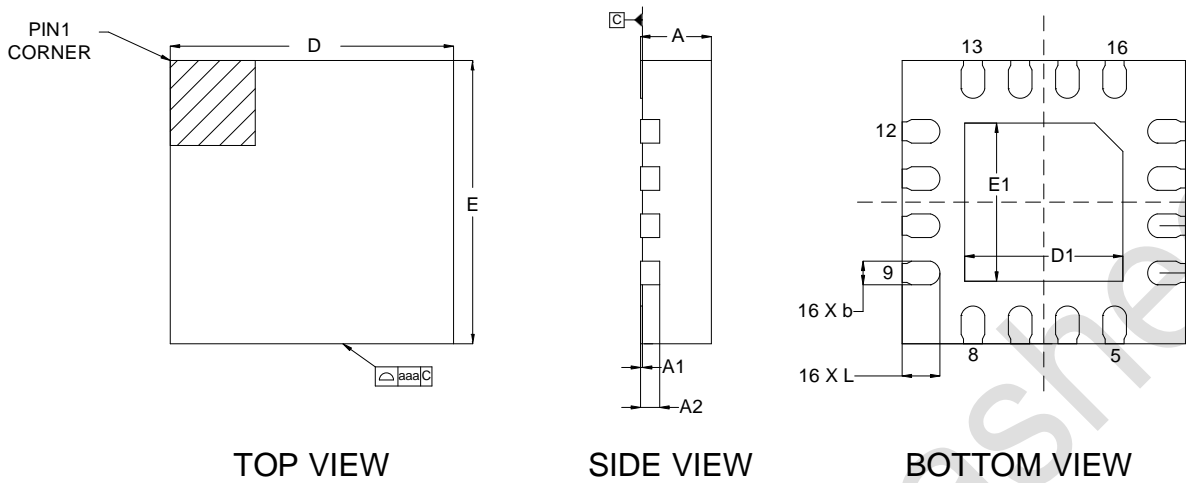

SYMBOLS	DIMENSION IN MILLIMETERS		
	MIN	NOM	MAX
A	0.700	0.750	0.800
A1	0.000	0.020	0.050
A2	0.203 REF		
b	0.180	0.250	0.300
D	3.000 BSC		
E	3.000 BSC		
D1	1.550	1.675	1.800
E1	1.550	1.675	1.800
e	0.500 BSC		
L	0.300	0.400	0.500
aaa	0.100		

Figure 5. QFN-16L Package, 3mm x 3mm

PACKAGE TOP MARKING

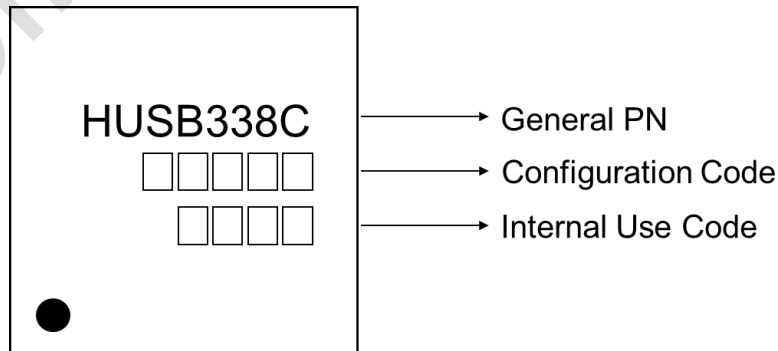

Figure 6. HUSB338C Package Top Marking

ORDERING GUIDE

Model	T _J Temp (°C)	Package Type	Package Option	Package Qty
HUSB338C_001UA	-40 to 125	QFN-16L, 3mm x 3mm	Tape & Reel	5000

Preliminary Datasheet

IMPORTANT NOTICE

Hynetek Semiconductor Co., Ltd. and its subsidiaries (Hynetek) reserve the right to make corrections, enhancements, improvements and other changes to its semiconductor products and services per JESD46, latest issue, and to discontinue any product or service per JESD48, latest issue. Buyers should obtain the latest relevant information before placing orders and should verify that such information is current and complete. All semiconductor products (also referred to herein as "components") are sold subject to Hynetek's terms and conditions of sale supplied at the time of order acknowledgment.

Hynetek warrants performance of its components to the specifications applicable at the time of sale, in accordance with the warranty in Hynetek's terms and conditions of sale of semiconductor products. Testing and other quality control techniques are used to the extent Hynetek deems necessary to support this warranty. Except where mandated by applicable law, testing of all parameters of each component is not necessarily performed.

Hynetek assumes no liability for applications assistance or the design of Buyers' products. Buyers are responsible for their products and applications using Hynetek components. To minimize the risks associated with Buyers' products and applications, Buyers should provide adequate design and operating safeguards.

Hynetek does not warrant or represent that any license, either express or implied, is granted under any patent right, copyright, mask work right, or other intellectual property right relating to any combination, machine, or process in which Hynetek components or services are used. Information published by Hynetek regarding third-party products or services does not constitute a license to use such products or services or a warranty or endorsement thereof. Use of such information may require a license from a third party under the patents or other intellectual property of the third party, or a license from Hynetek under the patents or other intellectual property of Hynetek.

Reproduction of significant portions of Hynetek information in Hynetek data books or data sheets is permissible only if reproduction is without alteration and is accompanied by all associated warranties, conditions, limitations, and notices. Hynetek is not responsible or liable for such altered documentation. Information of third parties may be subject to additional restrictions.

Resale of Hynetek components or services with statements different from or beyond the parameters stated by Hynetek for that component or service voids all express and any implied warranties for the associated Hynetek component or service and is an unfair and deceptive business practice.

Hynetek is not responsible or liable for any such statements.

Buyer acknowledges and agrees that it is solely responsible for compliance with all legal, regulatory and safety-related requirements concerning its products, and any use of Hynetek components in its applications, notwithstanding any applications-related information or support that may be provided by Hynetek. Buyer represents and agrees that it has all the necessary expertise to create and implement safeguards which anticipate dangerous consequences of failures, monitor failures and their consequences, lessen the likelihood of failures that might cause harm and take appropriate remedial actions. Buyer will fully indemnify Hynetek and its representatives against any damages arising out of the use of any Hynetek components in safety-critical applications.

In some cases, Hynetek components may be promoted specifically to facilitate safety-related applications. With such components, Hynetek's goal is to help enable customers to design and create their own end-product solutions that meet applicable functional safety standards and requirements. Nonetheless, such components are subject to these terms.

No Hynetek components are authorized for use in FDA Class III (or similar life-critical medical equipment) unless authorized officers of the parties have executed a special agreement specifically governing such use.

Only those Hynetek components which Hynetek has specifically designated as military grade or "enhanced plastic" are designed and intended for use in military/aerospace applications or environments. Buyer acknowledges and agrees that any military or aerospace use of Hynetek components which have not been so designated is solely at the Buyer's risk, and that Buyer is solely responsible for compliance with all legal and regulatory requirements in connection with such use.

Hynetek has specifically designated certain components as meeting ISO/TS16949 requirements, mainly for automotive use. In any case of use of non-designated products, Hynetek will not be responsible for any failure to meet ISO/TS16949.

Please refer to below URL for other products and solutions of Hynetek Semiconductor Co., Ltd.