

**• General Description**

It combines advanced trench MOSFET technology with a low resistance package to provide extremely low $R_{DS(ON)}$. This device is ideal for motor driver, load switch and DC-DC applications.

• Features

- Low $R_{DS(ON)}$ to minimize conductive loss
- Low Gate Charge for fast switching
- Low Thermal resistance
- Wettable Flanks

• Application

- BLDC Motor driver
- SMPS 2nd Synchronous Rectifier
- DC-DC

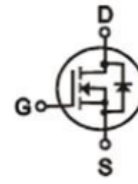
• Product Summary

$V_{DS} = 40V$

$R_{DS(ON)} = 1.1m\Omega$

$I_D = 290A$

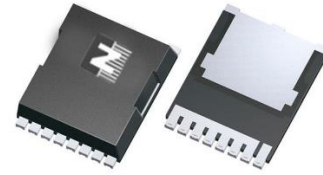

TOLL

**• Ordering Information:**

Part NO.	ZMS008N04R
Marking	ZMS008N04
Packing Information	REEL TAPE
Basic ordering unit (pcs)	800

• Absolute Maximum Ratings ($T_C=25^\circ C$)

Parameter	Symbol	Rating	Unit
Drain-Source Voltage	V_{DS}	40	V
Gate-Source Voltage	V_{GS}	± 20	V
Continuous Drain Current	$I_D @ T_C=25^\circ C$	290 ^①	A
	$I_D @ T_C=75^\circ C$	246	A
	$I_D @ T_C=100^\circ C$	182	A
Pulsed Drain Current ^②	I_{DM}	870	A
Total Power Dissipation	$P_D @ T_C=25^\circ C$	250	W
Total Power Dissipation ^③	$P_D @ T_A=25^\circ C$	4.2	W
Operating Junction Temperature	T_J	-55 to 150	$^\circ C$
Storage Temperature	T_{STG}	-55 to 150	$^\circ C$
Single Pulse Avalanche Energy ($L=0.5mH, V_{GS}=10V, R_g=25\Omega, T_J=25$)	E_{AS}	1200	mJ
Single Pulse Avalanche Energy ($L=0.1mH, V_{GS}=10V, R_g=25\Omega, T_J=25$)	E_{AS}	661	mJ



• Thermal resistance

Parameter	Symbol	Min.	Typ.	Max.	Unit
Thermal resistance, junction - case	R_{thJC}	-	-	0.5	$^{\circ}C/W$
Thermal resistance, junction - ambient	R_{thJA}	-	-	30	$^{\circ}C/W$
Soldering temperature, wave soldering for 10s	T_{sold}	-	-	265	$^{\circ}C$

• Electronic Characteristics

Parameter	Symbol	Condition	Min.	Typ	Max.	Unit
Drain-Source Breakdown Voltage	BV_{DSS}	$V_{GS} = 0V, I_D = 250\mu A$	40			V
Gate Threshold Voltage	$V_{GS(TH)}$	$V_{GS} = V_{DS}, I_D = 250\mu A$	1.4		2.5	V
Drain-Source Leakage Current	I_{DSS}	$V_{DS} = 40V, V_{GS} = 0V$			1.0	μA
Gate- Source Leakage Current	I_{GSS}	$V_{GS} = \pm 20V, V_{DS} = 0V$			± 100	nA
Static Drain-source On Resistance	$R_{DS(ON)}$	$V_{GS} = 10V, I_D = 50A$		1.1	1.43	m Ω
		$V_{GS} = 4.5V, I_D = 50A$		1.7	2.2	m Ω
Forward Transconductance	g_{FS}	$V_{DS} = 25V, I_D = 50A$		30		s
Source-drain voltage	V_{SD}	$I_S = 50A$			1.28	V

• Dynamic Characteristics

Parameter	Symbol	Condition	Min.	Typ	Max.	Unit
Input capacitance	C_{iss}	$f = 1MHz,$ $V_{DS} = 25V$	-	6270	-	pF
Output capacitance	C_{oss}		-	1770	-	
Reverse transfer capacitance	C_{rss}		-	103	-	
Gate Resistance	R_g	$f = 1MHz$		1.6		Ω
Total gate charge	Q_g	$V_{DD} = 20V$ $I_D = 20A$ $V_{GS} = 10V$	-	105	-	nC
Gate - Source charge	Q_{gs}		-	11	-	
Gate - Drain charge	Q_{gd}		-	32	-	
Turn-ON Delay time	$t_{D(on)}$	$V_{GS} = 10V,$ $V_{DS} = 15V$ $R_G = 6\Omega, I_D = 25A$		24		ns
Turn-ON Rise time	t_r			26		ns
Turn-Off Delay time	$t_{D(off)}$			66		ns
Turn-Off Fall time	t_f			17		ns
Reverse Recovery Time	t_{RR}	$V_{DD} = 20V,$ $dI_S/dt = 100$ $A/s, I_S = 30A$		66		ns
Charge Time	t_a			25		ns
Discharge Time	t_b			29		ns
Reverse Recovery Charge	Q_{RR}			96		nC



Fig.1 Power Dissipation

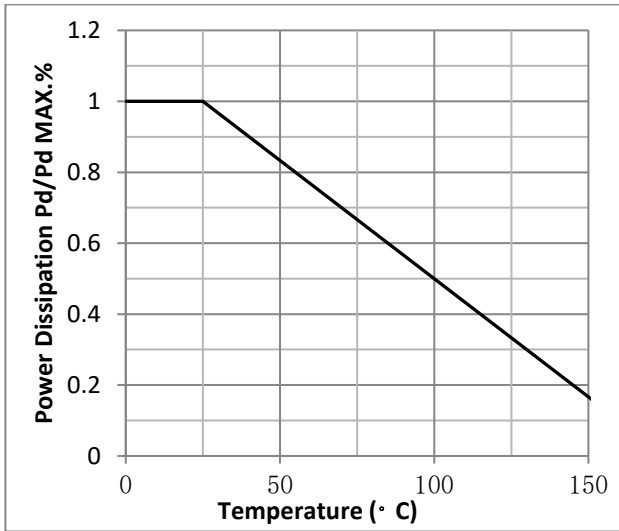

Fig.2 Typical output Characteristics

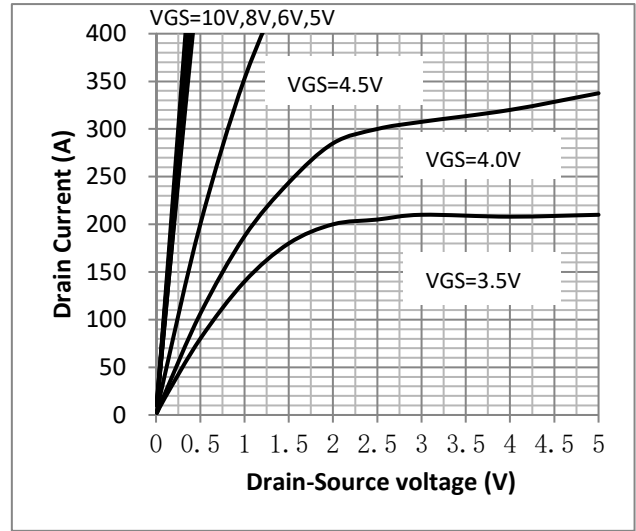

Fig.3 Threshold Voltage V.S Junction Temperature

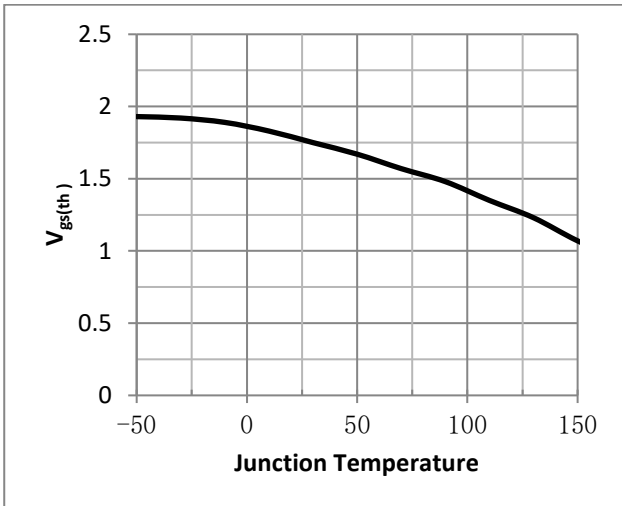

Fig.4 Resistance V.S Drain Current

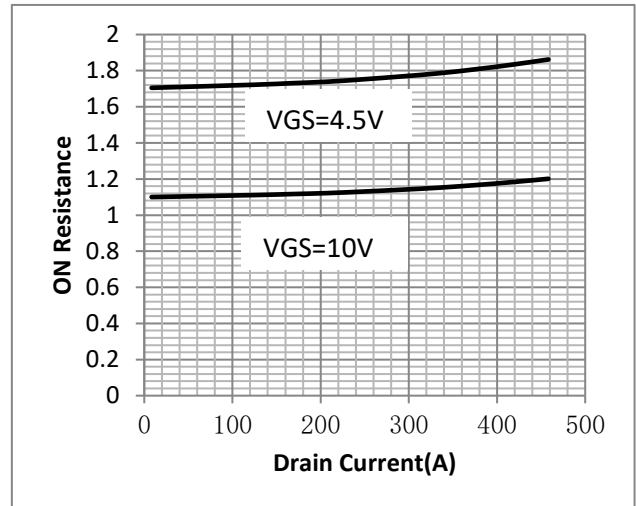

Fig.5 On-Resistance VS Gate Source Voltage

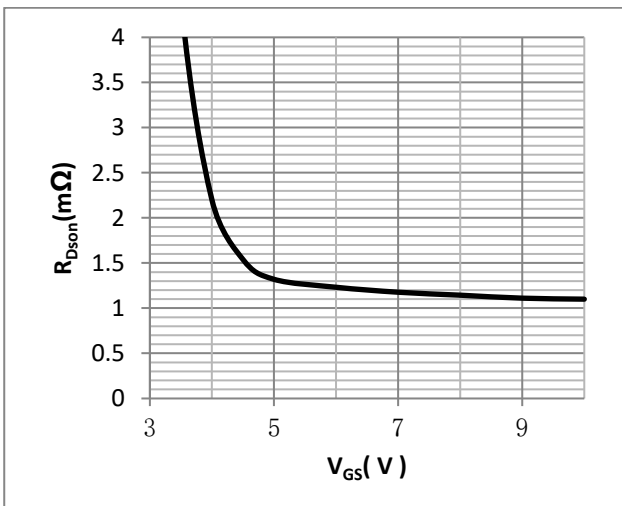

Fig.6 On-Resistance V.S Junction Temperature

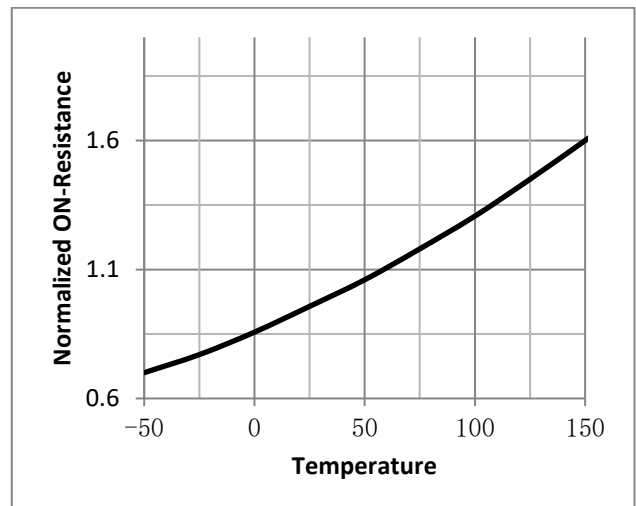



Fig.7 Gate Charge Characteristics

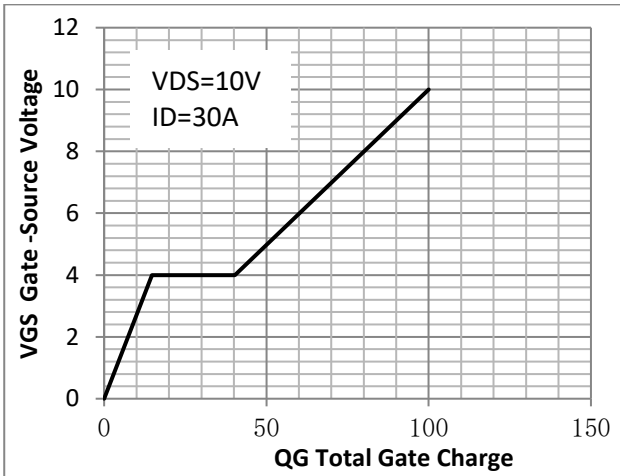

Fig.8 Capacitance vs Vds

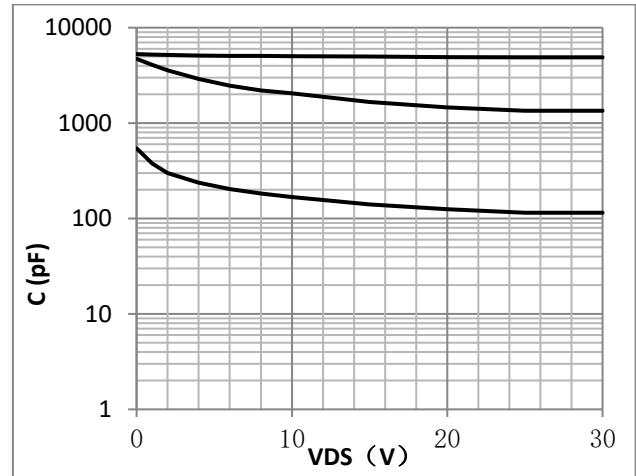

Fig.9 Diode Forward Voltage vs. Current

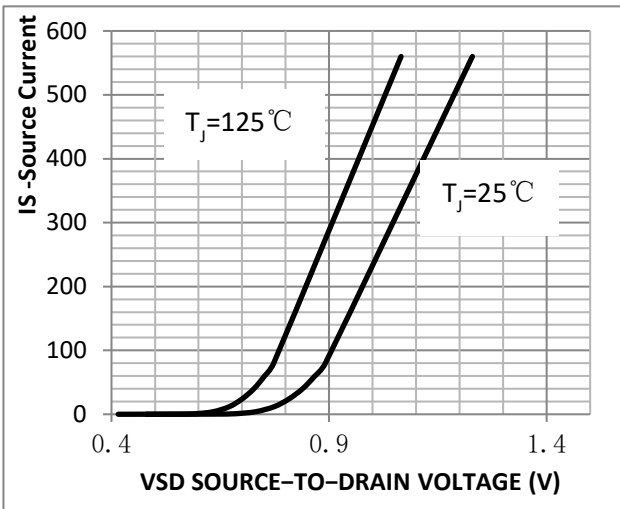

Fig.10 Capacitance Variation

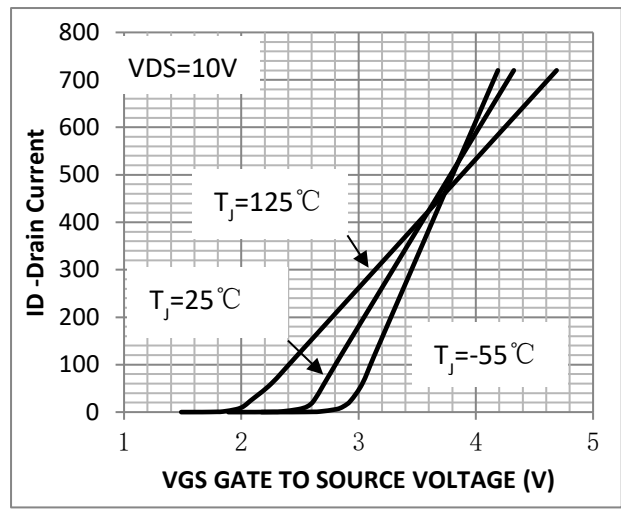

Fig.11 SOA Maximum Safe Operating Area

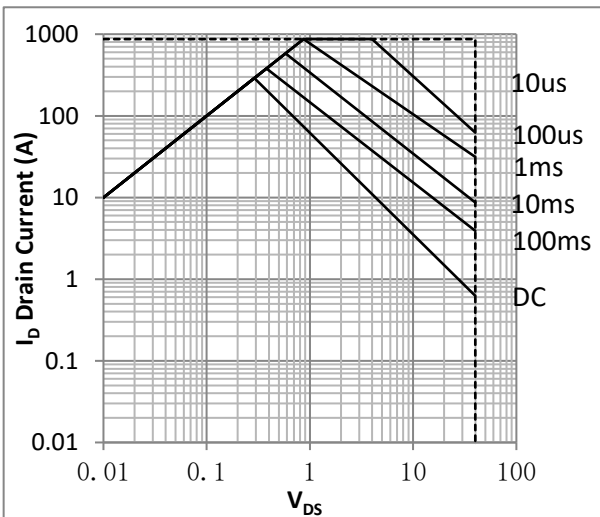

Fig.12 ID-Junction Temperature

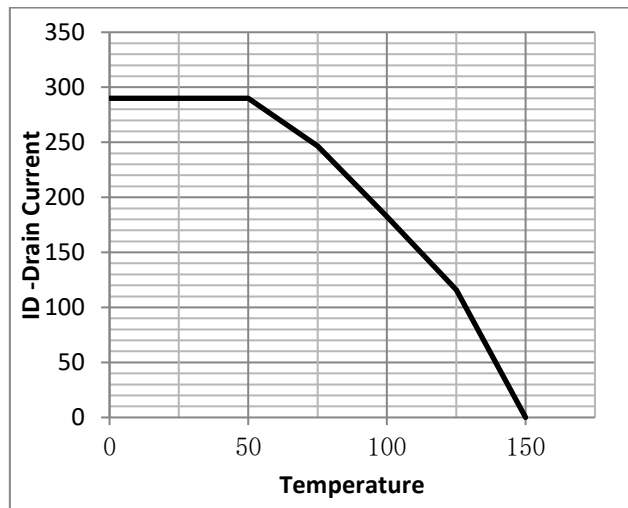



Fig.13 Normalized Maximum Transient Thermal Impedance

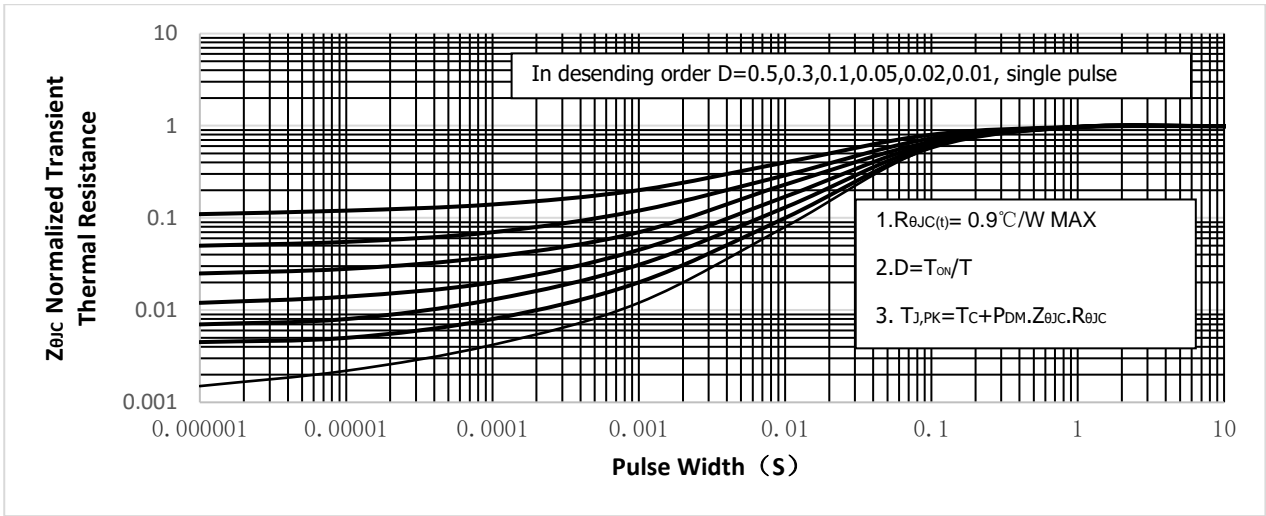

Fig.14 Switching Time Measurement Circuit

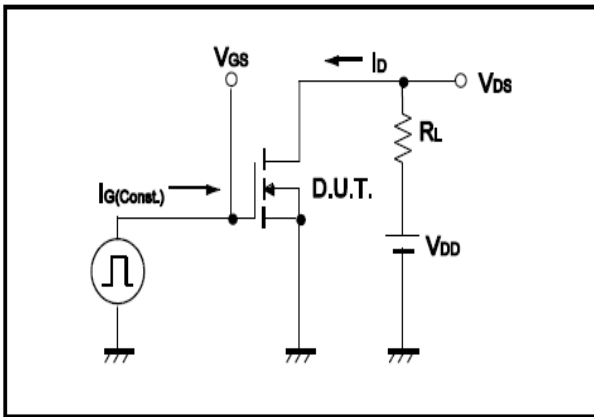

Fig.15 Gate Charge Waveform

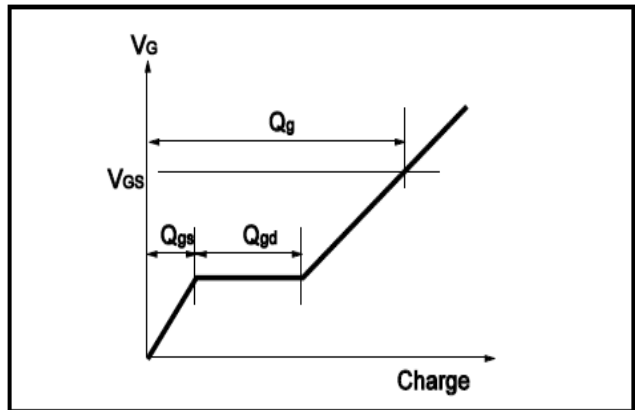

Fig.16 Resistive Switching Test Circuit

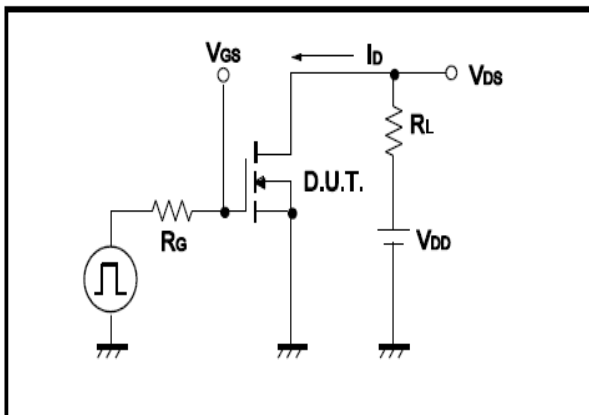

Fig.17 Resistive Switching Test Waveform

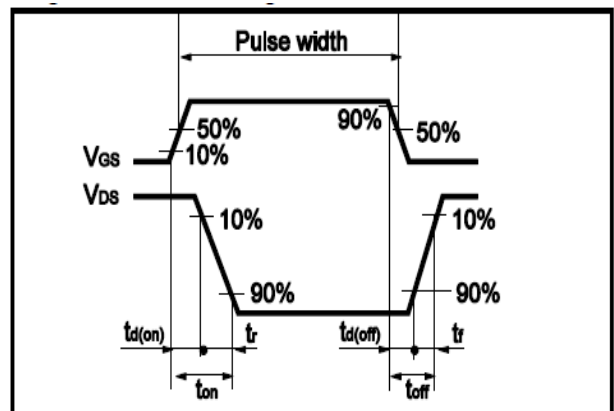



Fig.18 Avalanche Measurement Circuit

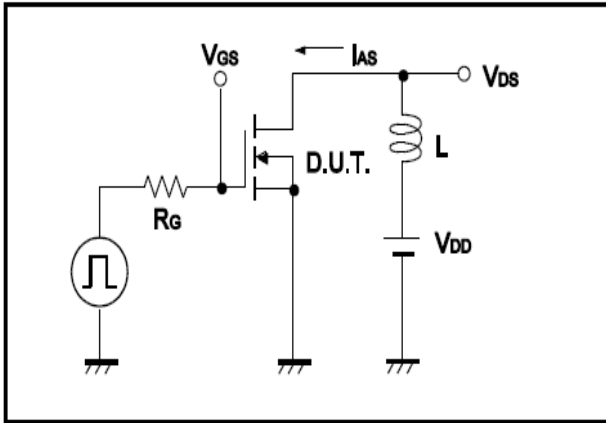
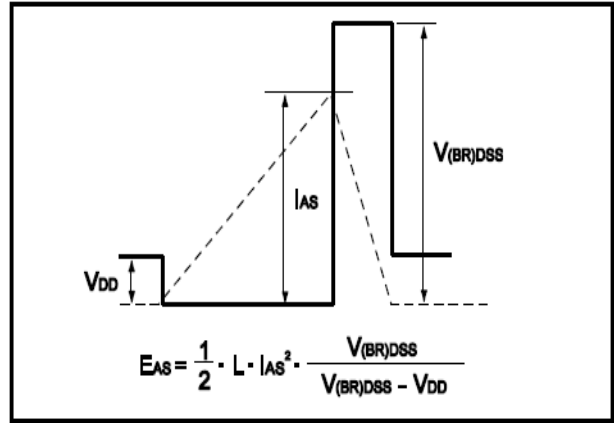

Fig.19 Avalanche Waveform





•Dimensions (TOLL)

Unit: mm

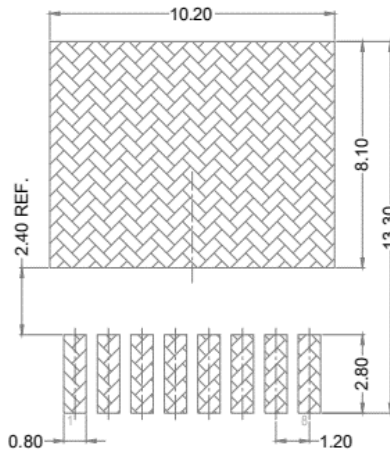
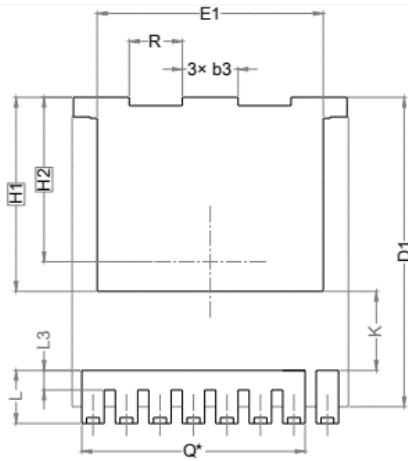
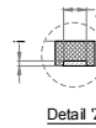
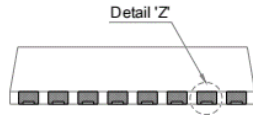
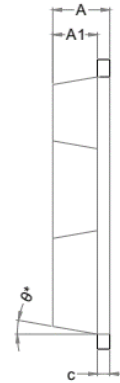
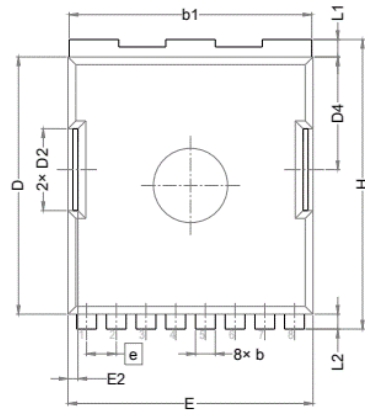

SYMBOL	DIMENSIONS		
	MIN.	NOM.	MAX.
A	2.20	2.30	2.40
A1	1.70	1.80	1.90
b	0.70	0.80	0.90
b1	9.70	9.80	9.90
b3	1.90	2.00	2.10
c	0.40	0.50	0.60
D	10.28	10.38	10.48
D1	10.98	11.08	11.18
D2	3.20	3.30	3.40
D4	4.45	4.55	4.65
E	9.80	9.90	10.00
E1	8.00	8.10	8.20
E2	0.30	0.40	0.50
e	1.20 BSC		
H	11.58	11.68	11.78
H1	6.95 BSC		
H2	5.89 BSC		
i	0.10 REF.		
j	0.46 REF.		
K	2.80 REF.		
L	1.60	1.90	2.10
L1	0.60	0.70	0.80
L2	0.50	0.60	0.70
L3	0.60	0.70	0.80
N	8		
Q	6.80 REF.		
R	1.80	1.90	2.00
θ	10° REF.		



Note:

- ① Limited by bonding wire
- ② Pulse Test : Pulse width $\leq 300\mu\text{s}$, Duty cycle $\leq 2\%$;
- ③ Device mounted on FR-4 substrate PC board, 2oz copper, with thermal bias to bottom layer 1inch square copper plate;